

KitchenAid®

FREESTANDING REFRIGERATION



KitchenAid®
FREESTANDING REFRIGERATION



A NEW ERA FOR KITCHENS

Taking its cues from the tools of culinary experts and master chefs, the distinct style of KitchenAid® appliances balances professionally-inspired aesthetics and high performance with a warm, non-commercial look suitable for the stylish home kitchen.

The suite is distinguished by satin-textured handles with functional and elegant cross-hatched grips, and the iconic medallion acts as a finishing stamp at both ends of each handle. Multi-finish knobs easily adjust and control power and are backlit from the bezel for dramatic effect. On select appliances, a chrome inlaid frame surrounds the viewing window, accenting the transition between the glass and brushed stainless steel surfaces.

KitchenAid





THE PERFECT MATCH FOR FRESH INGREDIENTS

KitchenAid® freestanding refrigerators offer two premium temperature management systems that help retain the taste and texture of fresh and frozen ingredients. They also provide many appetizing storage features to keep everything organized, and delicious design options – including the industry's first 5-door freestanding refrigerator – that create an ideal fit in most kitchens.



TEMPERATURE MANAGEMENT



PRESERVA[®] **FOOD CARE SYSTEM**

This innovative system combines three technologies that work together to manage humidity levels, reduce freezer burn, and help to eliminate odors. At the heart of the Preserva[®] Food Care System are sequential dual evaporators that create true independent cooling systems.



EXTENDFRESH[™] **TEMPERATURE MANAGEMENT SYSTEM**

A sensor-controlled system that detects when either the refrigerator or freezer is above the correct temperature. The sensors trigger the compressor to turn on and activate a fan that directs cool air into the desired compartment, helping to quickly lower temperatures to their appropriate level.





▲ Redefining the "Ice Box" ExtendFresh™ Temperature
▼ Preserva® Food Care System Management System

**TEMPERATURE
MANAGEMENT**



REDEFINING THE "ICE BOX"

THINK HEAT NOT COOL

The non-mechanical "ice box" was simple. Ice melted. Food got cold. The introduction of mechanical refrigerators with sealed cooling systems has taken food preservation a long way from these basic devices. However, if asked, most people would still say that a refrigerator makes, or blows, cold air.

But the cool air you feel from your refrigerator and freezer actually comes from moving, and removing, heat – not introducing cold air. In a matter of seconds, refrigerant changes from a high-pressure gas that wants to release heat to a low-pressure liquid that wants to absorb it.

HOW IT WORKS

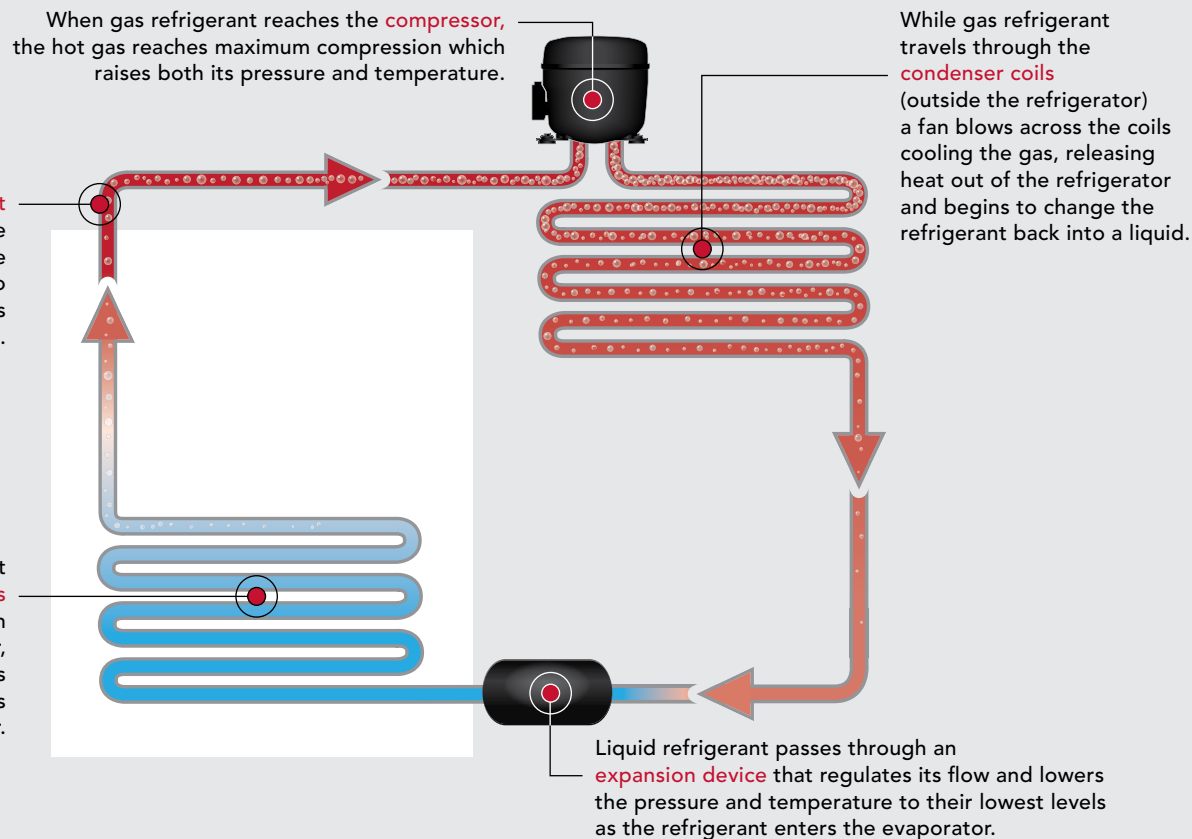

THREE COMPONENTS OF AN EFFECTIVE COOLING SYSTEM

Compressor

A motor and pump that moves refrigerant through the refrigerator and freezer.

Condenser Coils

The refrigerant cools as it flows through the condenser coils, dispelling the heat picked up inside the cooling system and returning the refrigerant to a liquid state.

Evaporator Coils

The tubing through which the liquid refrigerant flows. Refrigerant absorbs heat as it moves through the evaporator, which cools the refrigerator and freezer compartments.



PRESERVA® FOOD CARE SYSTEM

The Preserva® Food Care System combines three technologies to help manage humidity levels, assure crisp produce and eliminate odors inside the refrigerator. But an equally compelling benefit is the way it helps protect frozen items like ice cream from freezer burn that can harm its taste and texture.



DUAL EVAPORATORS

Provide a dedicated refrigeration unit to help keep food fresh longer and a separate system for frozen food.

1

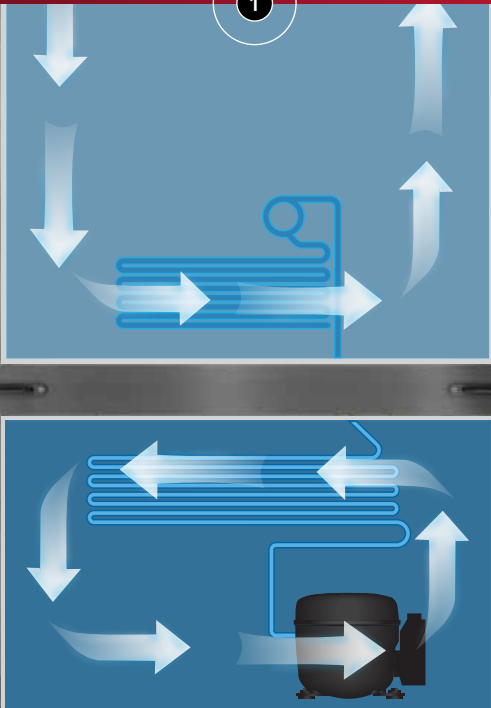

PRODUCE PRESERVER

Absorbs ethylene emitted by certain types of fresh produce to help delay over-ripening.*

* Based on commonly purchased produce.

2



FRESHFLOW™ AIR FILTER

15 times more effective than baking soda at reducing common food odors.

3





THE DUAL EVAPORATOR DIFFERENCE

Sequential dual evaporators change the way air flows through the refrigerator and the freezer. This is a key component to extending the life of fresh and frozen ingredients, particularly produce.

WHAT IS A DUAL EVAPORATOR SYSTEM?

A dual evaporator system has an independent evaporator inside the refrigerator in addition to the evaporator inside the freezer. Instead of receiving air that is blown in from the freezer, the refrigerator evaporates refrigerant at the temperature it requires. This creates more optimum climates for fresh and frozen food.



HOW IT WORKS

In a sequential dual evaporator system, the compressor pumps refrigerant through a sensor-driven control valve that directs the refrigerant to either the refrigerator or freezer evaporator on demand.

Refrigerant From Compressor

To Freezer

To Refrigerator



WHY HUMIDITY IS IMPORTANT

Culinary professionals understand that a failure to maintain the taste and texture of fresh and frozen ingredients is usually a humidity problem,



not a temperature problem. Dual evaporators allow cold, dry air from the freezer to stay in the freezer and cool, moist air in the refrigerator to stay in the refrigerator.

Even with dedicated drawers, sharing air between compartments compromises humidity levels in both.

IN THE FREEZER

LOW HUMIDITY REDUCES FREEZER BURN

With sequential dual evaporators, cold, dry air from the freezer (-10°F) does not mix with humid refrigerator air, reducing frost formation on ice cream and freezer burn in meats. Since no air mixes between the freezer and refrigerator, no odors transfer between compartments.

IN THE REFRIGERATOR

PRODUCE NEEDS HUMIDITY

Fruits and vegetables are composed mostly of water – with some containing as much as 96% water. To keep them fresh, they need to be stored in high humidity conditions. Having higher humidity in the refrigerator is particularly helpful for certain produce items.

From the farmer's market to the grocery store, there is a hunger to get educated about food. A KitchenAid® refrigerator with the Preserva® Food Care System **helps optimize taste and texture**, which means buying fresh ingredients with less concern about food spoilage.



THE KITCHENAID DIFFERENCE

Refrigerator cooling systems continue to evolve to meet consumer demand for energy efficiency. Features such as a variable capacity compressor and adaptive defrost are two ways KitchenAid® refrigerators promote reliable, efficient operation.



VARIABLE CAPACITY COMPRESSOR

When a traditional compressor starts from a dead stop, it requires a large amount of energy. And the frequent on/off cycling can also accelerate and shorten the useful life of system components.

The variable capacity compressor (VCC) gently ramps up from a dead start, allowing more efficient operation with less wear and tear on system components.

Refrigerator compressors operate most efficiently with a full load. However, most refrigerators are fully loaded only a fraction of the time.

A SMARTER WAY TO COOL

A variable capacity compressor promotes energy efficiency by delivering on-demand cooling.

ADAPTIVE DEFROST

Adaptive defrost electronically controls the frequency and length of the defrost cycle.

Many defrost systems operate on a timer, which means they operate at fixed time intervals whether defrosting is needed or not.

As the adaptive defrost cycle runs, the heating coils gently pulse on and off, helping to save energy and reducing the thawing and re-freezing that leads to freezer burn.

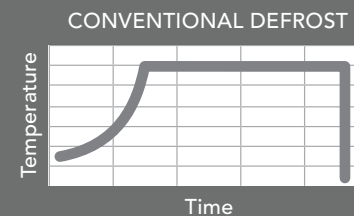
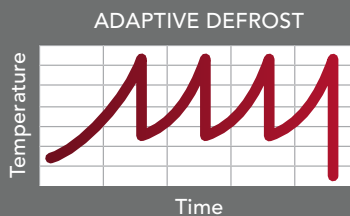



THE SCIENCE BEHIND KEEPING PRODUCE FRESH

A common consumer behavior is to use two crispers to divide fruits and vegetables. While this is a good guideline, it still is not the best way to keep produce fresh. This is due to the presence of ethylene.



Ethylene is an odorless gas that is a natural by-product of the ripening process.



ETHYLENE-PRODUCING FOODS

Some produce, like apples, pears and avocados continue to ripen after they are picked and emit ethylene. These items should be stored with each other.

ETHYLENE-SENSITIVE FOODS

Other produce, like lettuce, broccoli and watermelon, do not continue to ripen after they are picked, and will over-ripen if stored with ethylene producing foods in an enclosed space such as a crisper drawer.

PRODUCE PRESERVER

The Produce Preserver uses ethylene-absorption technology to help delay over-ripening of certain fruits and vegetables.* Place this cartridge in the crisper where ethylene-producing foods will be stored.

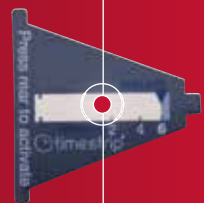

* Based on commonly purchased produce. For optimal performance, replace the Produce Preserver every six months.

A **visual indicator** lets you know when the ethylene filter should be replaced.



No matter how diligently you clean your refrigerator, food can spoil leaving unwanted odors and potentially bacteria that can transfer between foods.

FRESHFLOW™ AIR FILTER

The FreshFlow™ Air Filter uses activated carbon to reduce bacteria and refrigerator odors – like onions, garlic and fish – that can undermine flavor.

For optimal performance, replace the FreshFlow™ Air Filter every six months.

The FreshFlow™ Air Filter is **15 times more effective** than baking soda at reducing common food odors.



EXTENDFRESH™ TEMPERATURE MANAGEMENT SYSTEM

The ExtendFresh™ Temperature Management System features a single evaporator design that is enhanced by independent temperature controls inside the refrigerator and freezer to help ensure optimum storage of fresh and frozen food.



A fan helps cold freezer air circulate evenly throughout the compartment and ensures rapid cooling.

BAFFLE AND FAN

When the interior thermistors detect a temperature change inside the refrigerator, a baffle opens allowing cold air to enter the refrigerator compartment from the freezer.

INDEPENDENT SENSORS (THERMISTORS)

Allow more precise monitoring and control of temperatures inside the refrigerator and freezer compartments to ensure optimum storage of fresh and frozen food.

Thermistors inside the refrigerator and freezer compartments frequently measure temperatures to avoid large variations.

Inside the freezer,
a thermostat monitors
and controls temperatures.



CREATING THE PERFECT BALANCE

REFRIGERATED FOOD REQUIRES A HIGH LEVEL OF HUMIDITY

Food preservation is about managing temperature and humidity. Humidity-controlled crispers feature front and rear gaskets that create a tight seal so they can maintain a higher relative humidity level than the rest of the refrigerator.



For items that require **less humidity**, adjust the slide control to Fruit to let in more refrigerator air.

For items that need **more humidity**, move the slide control to Vegetables to seal the crisper.

FROZEN FOOD WANTS COLD, DRY AIR

If humidity enters the freezer, it can cause freezer burn and food spoilage. One way that moisture enters a freezer is during the defrost cycle when the compressor is off, raising the temperature inside the freezer.

ADAPTIVE DEFROST

KitchenAid® refrigerators have an energy-efficient, adaptive defrost cycle that operates only when needed.

During the defrost cycle, the heating coils gently pulse on and off which reduces the thawing and re-freezing that leads to freezer burn. Once the defrost cycle is complete, the compressor re-chills the cooling system to remove defrost heat before turning the air circulation fan back on.

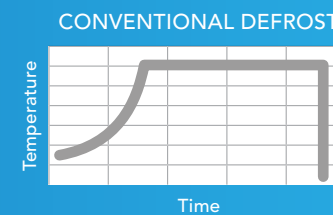
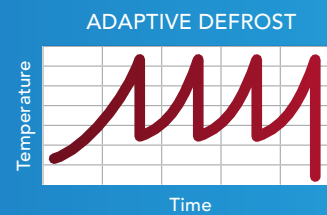
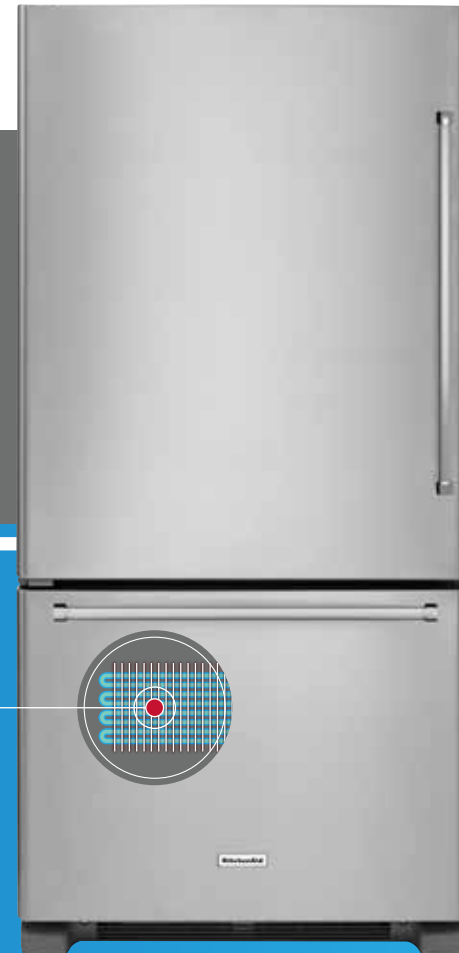

5-DOOR REFRIGERATORS



REVOLUTIONARY DESIGN

The industry-first 5-door configuration includes two exterior drawers: a temperature-controlled drawer with five electronic presets and a produce drawer that locks in humidity levels to help retain taste and texture.



PRESERVA[®] FOOD CARE SYSTEM

This innovative system combines three technologies that work together to manage humidity levels, reduce freezer burn, and help to eliminate odors.

More information about the Preserva[®] Food Care System can be found on pages 6-10.



PLATINUM INTERIOR

In addition to the 5-door configuration, this multi-door refrigerator features an industry-exclusive platinum interior design* that is accented by interior LED lighting.

* Model KRMF706E





Revolutionary Design

Flexible Storage Options

▲ Platinum Interior
▼ LED Lighting

Premium Features

Model Lineup

**5-DOOR
REFRIGERATORS**



A MULTI-LEVEL REVOLUTION

Refrigerator storage has taken many twists and turns through the years. Having the refrigerator below a freezer, above a freezer, next to a freezer and with French doors are just a few of the ways that manufacturers have tried to match refrigerator design and performance. The new KitchenAid® 5-door refrigerator takes refrigerator storage to a new level with dedicated compartments that provide adjustable climate control for different foods.

HOW REFRIGERATORS HAVE EVOLVED

Having a refrigerator in a home didn't become commonplace until after World War II. Since then, manufacturers have responded to consumers who have dictated the placement of the freezer and refrigerator based on which compartment they are likely to access most and what types of food they typically store.



- 1940s** Top-mount refrigerators (freezer on top/refrigerator on bottom) start to become a part of American homes.
- 1950s** The bottom-mount refrigerator (freezer on bottom/refrigerator on top) is introduced, allowing fresh food to be kept at eye level.
- 1960s** Side-by-side (left side freezer/right side refrigerator) otherwise known as the American-style refrigerator is introduced and shortly thereafter, the concept of an ice and water dispenser makes this a sought-after style.
- 1990s** French door refrigerators (freezer on bottom/two doors for refrigerator) give consumers the door swing of a side-by-side with the capacity and easy access of a traditional bottom-mount refrigerator.
- 2000s** Four door French door refrigerators (freezer on bottom/two doors for refrigerator and a separate refrigerator or freezer drawer) respond to the desire for dedicated storage of frequently accessed items, or the need to keep sensitive ingredients in their own climate.
- 2015** KitchenAid introduces the first freestanding refrigerator with a 5-door configuration.

TEMPERATURE-CONTROLLED DRAWER

This drawer allows five distinct food zones to be created depending on storage needs. Meat or Fish, Cold Drinks, Greens or Herbs, Deli or Cheese and Thaw or Marinate allow a precise temperature to be set within nine degrees of the refrigerator set point.



Each setting changes the internal temperature of the drawer for different items. For example, the Cold Drinks setting provides a quick chill to get beverages cold before serving, while selecting Thaw or Marinate allows meats to be kept in a proper environment before they need to be cooked.

PRODUCE DRAWER

In addition to providing ample storage for fresh-picked seasonal favorites, the produce drawer includes a Produce Preserver which absorbs ethylene gas that is produced by certain fruits and vegetables, and a removable divider that can allow contents to be easily organized. The sealed drawer helps to maximize humidity levels inside the drawer.



A **soft-close mechanism** allows the exterior drawers to close like fine furniture.



GET THE **INSIDE STORY**

This multi-door refrigerator delivers additional storage options that help retain the flavor of delicate ingredients like oregano, rosemary and thyme while making use of every inch of the refrigerator to keep food prep items close at hand.

An angled floor makes this compartment ideal for herb storage by keeping the stems wet without covering the leaves.



A full-width compartment makes clever use of previously unused space.



KitchenAid
Spill Control Edge

ADJUSTABLE SPILL-RESISTANT GLASS SHELVES

The interior shelves are easy to clean and help prevent messes from spilling over into other parts of the refrigerator. The shelf edges are nano-etched with a finely textured surface that helps contain spills.



With the **SatinGlide® System**, rollers and glides on the interior shelves and bins provide smooth, quiet operation.

Multi-Level Freezer Storage



SLIDE-AWAY SPLIT SHELF

The width of a refrigerator does nothing to make it easy to store tall items – until now. This slide-away split shelf allows half of the shelf to fold under itself to allow room for tall items without having to reorganize the entire refrigerator.



FRESH DESIGN THAT SHOWS GREAT TASTE

KitchenAid is known for developing innovative features that help meet unmet consumer needs. With the kitchen being such an integral part of entertaining, we've created a reason that will be appreciated every time guests take a look inside.

The industry-exclusive platinum finish makes colors appear to be more vibrant.

INDUSTRY-EXCLUSIVE PLATINUM INTERIOR

A glossy platinum finish on the interior walls of the refrigerator and freezer offers an attractive, elegant look that is a welcome contrast to a traditional white interior.

DESIGNED TO LAST - JUST WHAT YOU'D EXPECT FROM KITCHENAID BRAND

The platinum finish consists of three layers that are applied by a one-pass, rolled-on system to create an appliance-grade coating. This ensures that the finish will hold up to nicks and scratches.

- Polyester Top Coat
- Urethane Primer
- Polyester Backer
- Refrigerator Cabinet





BRIGHT IDEAS FOR FOOD STORAGE

Efficient LED lighting gradually increases to full intensity, similar to theater lighting. Multiple lights are purposefully placed throughout the refrigerator and freezer, including inside the crisper drawers, making it easy to find items.



SEE FOOD THE WAY IT WAS MEANT TO BE SEEN

An advanced interior under-shelf LED lighting system features a strip of 42 LED lights. This keeps food beautifully displayed by illuminating the area below the shelf and provides greater visibility.



LED lighting is an elegant complement to the platinum interior*
* Available on model KRMF706E.



PREMIUM FEATURES

1 AUTO-CLOSE DOORS

The French doors will softly pull themselves shut, helping to ensure the doors are not left ajar when arms are full of ingredients or groceries, or when they're frequently being opened while entertaining. The design also ensures that when one door closes, the other door will not pop open, removing a common concern with a French door design.

2 MEASURED WATER FILL

Displays and automatically dispenses water in ounces, cups or liters. It can be programmed to pour a measured amount, helping make food prep easier. It can even be set up to fill essential items on a daily basis like a coffee pot or a water bottle.

EXTERIOR ICE & WATER DISPENSER

An easy to use through-the-door system that filters water and ice for a fresh, clean taste and conveniently dispenses them outside the door of the refrigerator.

INTUITIVE CONTROLS

Make it easy to precisely adjust the temperature of both the refrigerator and freezer.

MAX ICE

A selectable option that speeds up the ice production rate during times when a large amount of ice is needed. The feature will stay active for 24 hours unless manually turned off.

MAX COOL

A selectable option that automatically drops the temperature in the refrigerator and freezer compartments to their lowest settings when adding a full grocery load, when the doors are being frequently opened and closed, or when the room temperature may be higher.

SABBATH MODE

When activated, this option turns off all non-essential functions in the refrigerator while not in use. It also modifies how often the compressor runs to maximize efficiency and save energy.



3 SATINGLIDE® CRISPERS

Provide a smooth experience to the crisper drawers. Rollers allow effortless in-and-out movement even when fully loaded.

4 EVERYDROP® ICE & WATER FILTER BY WHIRLPOOL® WATER

NSF certified to reduce the most contaminants* and filters approximately 200 gallons between filter changes.

* Based on NSF rated 6 month refrigerator filters flowing .75 gpm - .80 gpm.

5 IN-DOOR-ICE® DISPENSING SYSTEM

Adds interior room in the refrigerator with an ice bin that mounts on the inside left door of the refrigerator, keeping it out of the refrigerator compartment and allowing for extra shelf space.

AUTOMATIC ICE MAKER

Ensures a constant supply of ice for entertaining. The ice maker connects to the refrigerator with a water line.





5-DOOR REFRIGERATORS



KRMF606E - 36"

COLORS

- Stainless Steel (SS)

CAPACITIES (Cu. Ft.)

- 25.8 Total Volume

PERFORMANCE FEATURES

- Preserva® Food Care System
- Sequential Dual Evaporators
- FreshFlow™ Air Filter
- Produce Preserver (2)
- Adaptive Defrost
- Auto Humidity-Controlled Crispers
- Temperature-Controlled Drawer
- Produce Drawer
- Full-Width Sliding Drawer with Herb Storage
- Automatic Ice Maker
- In-Door-Ice® System
- EveryDrop® Ice & Water Filter
- Through-the-Door Ice & Water Dispenser
- Electronic Controls
- Control Lockout
- Measured Fill



KRMF706E - 36"

COLORS

- Stainless Steel (SS)

CAPACITIES (Cu. Ft.)

- 25.8 Total Volume

PERFORMANCE FEATURES

- Preserva® Food Care System
- Sequential Dual Evaporators
- FreshFlow™ Air Filter
- Produce Preserver (2)
- Adaptive Defrost
- Auto Humidity-Controlled Crispers
- Temperature-Controlled Drawer
- Produce Drawer
- Full-Width Sliding Drawer with Herb Storage
- Automatic Ice Maker
- In-Door-Ice® System
- EveryDrop® Ice & Water Filter
- Through-the-Door Ice & Water Dispenser
- Electronic Controls
- Control Lockout
- Measured Fill

CONTROL FEATURES

- °F/°C Temperature Display
- Door Alarm
- Water Filter Status Indicator
- Max Ice
- Max Cool
- Sabbath Mode (Star-K Certified)

DESIGN FEATURES

- Adjustable Spill-Resistant Glass Shelves with Spill Shield Technology
- Slide-Away Split Shelf
- Soft, Self-Close Drawers
- Auto Close Doors
- SatinGlide® System
- Adjustable Door Bins with Removable Insert
- Gallon Door Storage
- 3-Tier Freezer Drawer with SatinGlide® Baskets/Bins
- LED Ramp-Up Theater Lighting
- Under-Shelf LED Lighting
- Hidden Hinges
- Front-Adjustable Leveling Legs
- Metallic Trim

CONTROL FEATURES

- °F/°C Temperature Display
- Door Alarm
- Water Filter Status Indicator
- Max Ice
- Max Cool
- Sabbath Mode (Star-K Certified)

DESIGN FEATURES

- Adjustable Spill-Resistant Glass Shelves with Spill Shield Technology
- Slide-Away Split Shelf
- Soft, Self-Close Drawers
- Auto Close Doors
- SatinGlide® System
- Adjustable Door Bins with Removable Insert
- Gallon Door Storage
- 3-Tier Freezer Drawer with SatinGlide® Baskets/Bins
- LED Ramp-Up Theater Lighting
- Under-Shelf LED Lighting
- Hidden Hinges
- Front-Adjustable Leveling Legs
- Metallic Trim
- **Platinum Interior**

Red text = step-up feature

BOTTOM-FREEZER REFRIGERATORS



TEMPERATURE MANAGEMENT

Select KitchenAid® French door refrigerators feature the Preserva® Food Care System. All traditional bottom-freezer and select French door refrigerators feature the ExtendFresh™ Temperature Management System.

More information about our temperature management systems can be found on pages 6-12.



DESIGN OPTIONS

KitchenAid® freestanding refrigerators make it possible for consumers to maximize the efficiency of their kitchen.



SPECIALIZED INGREDIENT CARE

From humidity-controlled crispers to a Produce Preserver that absorbs ethylene gas, KitchenAid® French door and bottom-freezer refrigerators provide options to help maintain the taste and texture of fresh ingredients.





▲ Design Options

▼ Specialized Ingredient Care

Premium Features

Model Lineup

**BOTTOM-FREEZER
REFRIGERATORS**



DESIGN OPTIONS

In most kitchens, the refrigerator is virtually impossible to hide. However, refrigerator design has come a long way and consumers who are replacing a 10-year old refrigerator will find they have more options to consider.

A 33-inch wide refrigerator gives space-challenged remodelers an attractive alternative with more capacity than a 30-inch wide refrigerator.



HELP THEIR REFRIGERATOR FIT LIKE A GLOVE

Consumers need to measure the width and height of their cabinet opening to ensure proper installation of their freestanding refrigerator.

- French door and bottom-freezer refrigerators fit in spaces as wide as 36 inches and as narrow as 30 inches
- The shortest KitchenAid® refrigerator is 66 inches high*, which is ideal for consumers who have limited space available
- A 72-inch high refrigerator is an alternative for customers who find that a 69-inch high refrigerator leaves too much of a gap below overhead cabinets

* To the top of the cabinet.

STANDARD-DEPTH

These refrigerators have a cabinet that extends beyond the front of a 24-inch base cabinet. They work well in large, spacious kitchens and offer the benefit of larger overall storage than a counter-depth refrigerator.



COUNTER-DEPTH

These refrigerators have a cabinet that is 24 inches deep, so only the door and handles extend beyond the front of a standard base cabinet. This creates improved traffic flow around the refrigerator, particularly with the doors open.



SPECIALIZED INGREDIENT CARE

In addition to providing eye-level access to refrigerated food, KitchenAid® French door and bottom-freezer refrigerators have features that create storage options for sensitive ingredients like produce.

ELECTRONIC TEMPERATURE-CONTROLLED PANTRY*

Provides precise settings for meats, deli items, party platters, and wine. Pressing the Preset control displays the factory set temperature for each setting. Electronic controls allow you to adjust the temperature up or down as needed.



* On French Door Refrigerators with the Preserva® Food Care System.

Slide-Away Split Shelf 1

Metal Wine Rack 2

Humidity-Controlled Crispers 3

FreshChill™ Temperature-Controlled Full-Width Pantry** 4

** On French Door Refrigerators with the ExtendFresh™ Temperature Management System.





PREMIUM FEATURES*

1 SLIDE-AWAY SPLIT SHELF

Helps maximize the storage space and optimize the organization of your refrigerator. The versatile design allows the front of the shelf to retract to accommodate tall items.

2 METAL WINE RACK

Provides a durable storage solution for up to four bottles of wine or 2-liter containers and can be removed for additional storage flexibility.

HUMIDITY-CONTROLLED CRISPERS

Provide a dedicated storage option with adjustable humidity levels to keep fresh food in an optimal environment.

SATINGLIDE® SYSTEM

Uses space-efficient, under-mounted pans with rollers and glides for satisfyingly smooth operation.

MAX COOL

When selected, this feature automatically adjusts the temperature in the refrigerator and freezer to the lowest setting when appropriate. This keeps the refrigerator at the ideal temperature when loading groceries, the doors are frequently opened or in higher room temperatures.

MEASURED FILL

Displays and automatically dispenses water in ounces, cups or liters. It can be programmed to pour a measured amount, helping make food prep easier. It can even be set up to fill essential items on a daily basis like a coffee pot or a water bottle.

ADJUSTABLE DOOR BINS WITH REMOVABLE INSERTS

Convenient storage bins with specially designed, dishwasher-safe inserts keep items like condiments organized and readily available for food preparation or serving.



* On select models.

3 FRESHCHILL™ TEMPERATURE-CONTROLLED FULL-WIDTH PANTRY

A storage drawer that allows users to adjust the amount of cold air that enters. Meats can be kept at a temperature that is colder than the rest of the refrigerator and produce can be sealed off from the air flowing through the refrigerator compartment.

4 PRODUCE PRESERVER

An ethylene-absorbing cartridge that extends the freshness of produce.* It helps neutralize the over-ripening effects of ethylene gas that is naturally emitted by certain fruits and vegetables.

* Based on commonly purchased produce.

5 EVERYDROP® ICE & WATER FILTER BY WHIRLPOOL® WATER

NSF certified to reduce the most contaminants* and filters approximately 200 gallons between filter changes.

* Based on NSF rated 6 month refrigerator filters flowing .50 gpm - .60 gpm.

LED LIGHTING

Illuminates the inside of the refrigerator and freezer for better visibility. Unlike incandescent bulbs, LED lights use less energy, are maintenance-free and never need to be replaced.

MULTI-LEVEL FREEZER STORAGE

Keeps freezer items organized. Depending on the model selected, the freezer will have two or three levels of storage. Storage dividers add an extra layer of organization.

UNDERSHELF LIGHTING

Featured on Model KRFF707E, this feature puts light right where you need it, making it easy to find items no matter where they are inside the refrigerator.

PLATINUM INTERIOR

Featured on Model KRFF707E, this feature provides a premium look with silver glossy walls that complement the metallic accents found inside the refrigerator.





STANDARD-DEPTH FRENCH DOOR REFRIGERATORS



KRFF300E - 30"



KRFF302E - 33"



KRFF305E - 36"



KRFF507E - 36"



KRFF707E - 36"

COLORS

- White (WH)
- Black (BL)
- Stainless Steel (SS)

COLORS

- White (WH)
- Black (BL)
- Stainless Steel (SS)

COLORS

- White (WH)
- Black (BL)
- Stainless Steel (SS)

COLORS

- White (WH)
- Black (BL)
- Stainless Steel (SS)

COLORS

- Stainless Steel (SS)

CAPACITIES (Cu. Ft.)

- 19.69 Total Volume

CAPACITIES (Cu. Ft.)

- 22.1 Total Volume

CAPACITIES (Cu. Ft.)

- 25.2 Total Volume

CAPACITIES (Cu. Ft.)

- 26.8 Total Volume

CAPACITIES (Cu. Ft.)

- 26.8 Total Volume

PERFORMANCE FEATURES

- ExtendFresh™ Temperature Management System
- FreshFlow™ Air Filter
- Produce Preserver
- Adaptive Defrost
- FreshChill™ Temperature-Controlled Full-Width Pantry
- Humidity-Controlled Crispers
- Automatic Ice Maker
- Interior Water Dispenser
- EveryDrop® Ice & Water Filter

PERFORMANCE FEATURES

- ExtendFresh™ Temperature Management System
- Produce Preserver
- Adaptive Defrost
- FreshChill™ Temperature-Controlled Full-Width Pantry
- Humidity-Controlled Crispers
- Automatic Ice Maker
- Interior Water Dispenser
- EveryDrop® Ice & Water Filter

PERFORMANCE FEATURES

- ExtendFresh™ Temperature Management System
- Produce Preserver
- Adaptive Defrost
- FreshChill™ Temperature-Controlled Full-Width Pantry
- Humidity-Controlled Crispers
- Automatic Ice Maker
- Interior Water Dispenser
- EveryDrop® Ice & Water Filter

PERFORMANCE FEATURES

- Preserva® Food Care System with Sequential Dual Evaporators
- FreshFlow™ Air Filter
- Produce Preserver
- Adaptive Defrost
- Electronic Temperature-Controlled Pantry
- Auto Humidity-Controlled Crispers
- Automatic Ice Maker
- In-Door-Ice® System
- Through-the-Door Ice & Water Dispenser
- EveryDrop® Ice & Water Filter
- Measured Fill

PERFORMANCE FEATURES

- Preserva® Food Care System with Sequential Dual Evaporators
- FreshFlow™ Air Filter
- Produce Preserver
- Adaptive Defrost
- Electronic Temperature-Controlled Pantry
- Auto Humidity-Controlled Crispers
- Automatic Ice Maker
- In-Door-Ice® System
- Through-the-Door Ice & Water Dispenser
- EveryDrop® Ice & Water Filter
- Measured Fill

Red text = step-up feature

CONTROL FEATURES

- °F/°C Temperature Display
- Door Alarm
- Water Filter Status Indicator
- Max Cool
- Sabbath Mode (Star-K Certified)

CONTROL FEATURES

- °F/°C Temperature Display
- Door Alarm
- Water Filter Status Indicator
- Max Cool

CONTROL FEATURES

- °F/°C Temperature Display
- Door Alarm
- Water Filter Status Indicator
- Max Cool

CONTROL FEATURES

- °F/°C Temperature Display
- Door Alarm
- Water Filter Status Indicator
- Max Cool
- Sabbath Mode (Star-K Certified)

CONTROL FEATURES

- °F/°C Temperature Display
- Door Alarm
- Water Filter Status Indicator
- Max Cool
- Sabbath Mode (Star-K Certified)

DESIGN FEATURES

- Adjustable Spill-Resistant Glass Shelves
- 2 Slide-Away Split Shelves

DESIGN FEATURES

- Adjustable Spill-Resistant Glass Shelves
- Slide-Away Split Shelf

DESIGN FEATURES

- Adjustable Spill-Resistant Glass Shelves
- Slide-Away Split Shelf

DESIGN FEATURES

- **Adjustable Spill-Resistant Glass Shelves with Spill Shield Technology**
- Slide-Away Split Shelf

DESIGN FEATURES

- Adjustable Spill-Resistant Glass Shelves with Spill Shield Technology

- Adjustable Door Bins

- **SatinGlide® System**
- Adjustable Door Bins

- SatinGlide® System
- Adjustable Door Bins

- SatinGlide® System
- **Adjustable Door Bins with Removable Insert**
- Gallon Door Storage

- **Undershelf LED Lighting**
- SatinGlide® System
- Adjustable Door Bins with Removable Insert
- Gallon Door Storage

- Gallon Door Storage
- Metal Wine Rack
- 2-Tier Freezer Drawer

- Gallon Door Storage
- Metal Wine Rack
- 2-Tier Freezer Drawer

- Gallon Door Storage
- Metal Wine Rack
- 2-Tier Freezer Drawer

- 2-Tier Freezer Drawer
- **Storage Divider in Upper and Lower Baskets**

- **Metal Wine Rack**
- **3-Tier Freezer Drawer**
- Storage Divider in Lower Basket

- ClearVue™ LED Theater Lighting
- Hidden Hinges
- Front-Adjustable Leveling Legs
- Metallic Trim

- Hidden Hinges
- Front-Adjustable Leveling Legs
- Metallic Trim

- Hidden Hinges
- Front-Adjustable Leveling Legs
- Metallic Trim

- **ClearVue™ LED Theater Lighting**
- Hidden Hinges
- Front-Adjustable Leveling Legs
- Metallic Trim

- **Platinum Interior**
- ClearVue™ LED Theater Lighting
- Hidden Hinges
- Front-Adjustable Leveling Legs
- Metallic Trim

ENERGY EFFICIENCY

- ENERGY STAR® Qualified

ENERGY EFFICIENCY

- ENERGY STAR® Qualified

ENERGY EFFICIENCY

- ENERGY STAR® Qualified

Red text = step-up feature

COUNTER-DEPTH FRENCH DOOR REFRIGERATORS ON FOLLOWING PAGE



COUNTER-DEPTH FRENCH DOOR REFRIGERATORS

STANDARD-DEPTH FRENCH DOOR REFRIGERATORS ON PREVIOUS PAGE



KRFC300E - 36"

COLORS

- White (WH)
- Black (BL)
- Stainless Steel (SS)

CAPACITIES (Cu. Ft.)

- 20.0 Total Volume

PERFORMANCE FEATURES

- ExtendFresh™ Temperature Management System
- Produce Preserver
- Adaptive Defrost
- FreshChill™ Temperature-Controlled Full-Width Pantry
- Humidity-Controlled Crispers
- Automatic Ice Maker
- Interior Water Dispenser
- EveryDrop® Ice & Water Filter



KRFC302E - 36"

COLORS

- White (WH)
- Black (BL)
- Stainless Steel (SS)
- Panel-Ready (PA)

CAPACITIES (Cu. Ft.)

- 21.9 Total Volume

PERFORMANCE FEATURES

- ExtendFresh™ Temperature Management System
- Produce Preserver
- Adaptive Defrost
- FreshChill™ Temperature-Controlled Full-Width Pantry
- Humidity-Controlled Crispers
- Automatic Ice Maker
- Interior Water Dispenser
- EveryDrop® Ice & Water Filter



KRFC400E - 36"

COLORS

- White (WH)
- Black (BL)
- Stainless Steel (SS)

CAPACITIES (Cu. Ft.)

- 19.7 Total Volume

PERFORMANCE FEATURES

- ExtendFresh™ Temperature Management System
- Produce Preserver
- Adaptive Defrost
- FreshChill™ Temperature-Controlled Full-Width Pantry
- Humidity-Controlled Crispers
- Automatic Ice Maker
- **Through-the-Door Ice & Water Dispenser**
- EveryDrop® Ice & Water Filter
- LCD Display

Red text = step-up feature

CONTROL FEATURES

- °F/°C Temperature Display
- Door Alarm
- Water Filter Status Indicator
- Max Cool

DESIGN FEATURES

- Adjustable Spill-Resistant Glass Shelves
 - SatinGlide® System
 - Adjustable Door Bins
 - Gallon Door Storage
 - Metal Wine Rack
-
- 2-Tier Freezer Drawer
-
- Hidden Hinges
 - Front-Adjustable Leveling Legs
 - Metallic Trim

ENERGY EFFICIENCY

- ENERGY STAR® Qualified

CONTROL FEATURES

- °F/°C Temperature Display
- Door Alarm
- Water Filter Status Indicator
- Max Cool
- Sabbath Mode (Star-K Certified)

DESIGN FEATURES

- Adjustable Spill-Resistant Glass Shelves
 - SatinGlide® Max System
 - Adjustable Door Bins
 - Gallon Door Storage
 - Metal Wine Rack
-
- **3-Tier Freezer Drawer**
-
- Hidden Hinges
 - Front-Adjustable Leveling Legs
 - Metallic Trim

CONTROL FEATURES

- °F/°C Temperature Display
- Door Alarm
- Water Filter Status Indicator
- Max Cool
- Vacation Mode

DESIGN FEATURES

- SatinGlide® System
- Adjustable Door Bins
- Gallon Door Storage
- Metal Wine Rack
- **2 Condiment Caddies**
- 2-Tier Freezer Drawer
- **Storage Divider in Lower Basket**
- Hidden Hinges
- Front-Adjustable Leveling Legs

Red text = step-up feature



BOTTOM-FREEZER REFRIGERATORS



KRBL109E - 30"
KRBR109E - 30"

CONFIGURATIONS

- Left-Hand Door Swing (KRBL109E)
- Right-Hand Door Swing (KRBR109E)

COLORS

- Stainless Steel (SS)

CAPACITIES (Cu. Ft.)

- 18.67 Total Volume

PERFORMANCE FEATURES

- ExtendFresh™ Temperature Management System
- Produce Preserver
- Adaptive Defrost
- Full-Width Pantry
- Humidity-Controlled Crispers



KRBX109E - 30"

CONFIGURATIONS

- Reversible Door Swing

COLORS

- White (WH)
- Black (BL)

CAPACITIES (Cu. Ft.)

- 18.67 Total Volume

PERFORMANCE FEATURES

- ExtendFresh™ Temperature Management System
- Produce Preserver
- Adaptive Defrost
- Full-Width Pantry
- Humidity-Controlled Crispers



KRBL102E - 33"
KRBR102E - 33"

CONFIGURATIONS

- Left-Hand Door Swing (KRBL102E)
- Right-Hand Door Swing (KRBR102E)

COLORS

- Stainless Steel (SS)

CAPACITIES (Cu. Ft.)

- 22.1 Total Volume

PERFORMANCE FEATURES

- ExtendFresh™ Temperature Management System
- Produce Preserver
- Adaptive Defrost
- Full-Width Pantry
- Humidity-Controlled Crispers



KRBX102E - 33"

CONFIGURATIONS

- Reversible Door Swing

COLORS

- White (WH)
- Black (BL)

CAPACITIES (Cu. Ft.)

- 22.1 Total Volume

PERFORMANCE FEATURES

- ExtendFresh™ Temperature Management System
- Produce Preserver
- Adaptive Defrost
- Full-Width Pantry
- Humidity-Controlled Crispers

CONTROL FEATURES

- °F/°C Temperature Display

DESIGN FEATURES

- Adjustable Spill-Resistant Glass Shelves
- Adjustable Door Bins
- Gallon Door Storage
- Metal Wine Rack
- 2 Pull-Out Freezer Baskets
- LED Lighting
- Front-Adjustable Leveling Legs

ENERGY EFFICIENCY

- ENERGY STAR® Qualified

ACCESSORIES

- Ice Maker Kit

CONTROL FEATURES

- °F/°C Temperature Display

DESIGN FEATURES

- Adjustable Spill-Resistant Glass Shelves
- Adjustable Door Bins
- Gallon Door Storage
- Metal Wine Rack
- 2 Pull-Out Freezer Baskets
- LED Lighting
- Front-Adjustable Leveling Legs

ENERGY EFFICIENCY

- ENERGY STAR® Qualified

ACCESSORIES

- Ice Maker Kit

CONTROL FEATURES

- °F/°C Temperature Display

DESIGN FEATURES

- Adjustable Spill-Resistant Glass Shelves
- Adjustable Door Bins
- Gallon Door Storage
- Metal Wine Rack
- 2 Pull-Out Freezer Baskets
- LED Lighting
- Front-Adjustable Leveling Legs

ENERGY EFFICIENCY

- ENERGY STAR® Qualified

ACCESSORIES

- Ice Maker Kit

CONTROL FEATURES

- °F/°C Temperature Display

DESIGN FEATURES

- Adjustable Spill-Resistant Glass Shelves
- Adjustable Door Bins
- Gallon Door Storage
- Metal Wine Rack
- 2 Pull-Out Freezer Baskets
- LED Lighting
- Front-Adjustable Leveling Legs

ENERGY EFFICIENCY

- ENERGY STAR® Qualified

ACCESSORIES

- Ice Maker Kit

SIDE-BY-SIDE REFRIGERATORS



PRESERVA[®] **FOOD CARE** **SYSTEM**

This innovative system combines three technologies that work together to manage humidity levels, reduce freezer burn, and help to eliminate odors.

More information about the Preserva[®] Food Care System can be found on pages 6-10.



CONFIGURATION **AND DESIGN** **OPTIONS**

Side-by-side refrigerators create flexible storage options for both the refrigerator and the freezer. Adjustable shelves and door bins allow you to easily organize your food and keep frequently accessed items in both compartments within easy reach.







PREMIUM FEATURES

1 CLEAR DOOR BINS WITH METALLIC ACCENTS

Allow you to see labels right through the bins, helping you keep condiments and other items organized. Each bin is removable, making it easy to pull out, chop up and store amazingly fresh produce, and simply slide back into the refrigerator.

2 METAL WINE RACK

Provides a durable storage solution for up to four bottles of wine or 2-liter containers and can be removed for additional storage flexibility.

3 LED LIGHTING WITH TOWER

In addition to individual lights along the top and sides of the cabinet, the refrigerator compartment has a tower that provides elegant back lighting to enhance visibility. The maintenance-free LED lights never need to be replaced.

4 METALLIC ACCENTS ON SHELF TRIM

Rich metallic trim is applied to the leading edges of the refrigerator shelves, complementing the gloss finish of the interior.

5 ADJUSTABLE SPILL-RESISTANT SHELVES

Prevent messes from spilling over into other parts of the refrigerator. In place of a lip that can trap foods, the shelf edges are nano-etched with a finely textured surface that contains spills and lets you use the whole shelf from edge-to-edge.



6 HUMIDITY-CONTROLLED CRISPERS

Provide a dedicated storage option with adjustable humidity levels to keep fresh food in an optimal environment.

7 EXTERIOR ICE & WATER DISPENSER

Provides freshly filtered, great tasting water and ice that can be conveniently found right in the refrigerator door.

8 MEASURED FILL

Displays and automatically dispenses water in ounces, cups or liters. It can be programmed to pour a measured amount, helping make food prep easier. It can even be set up to fill essential items on a daily basis like a coffee pot or a water bottle.

9 IN-DOOR-ICE® SYSTEM

Adds interior room in the refrigerator with an ice bin that mounts on the inside left door of the refrigerator, keeping it out of the refrigerator compartment and allowing for extra shelf space.

10 FRESHFLOW™ AIR FILTER

Is 15 times more effective than baking soda at reducing common food odors.

EVERYDROP® ICE & WATER FILTER BY WHIRLPOOL® WATER

NSF certified to reduce the most contaminants* and filters approximately 200 gallons between filter changes.

* Based on NSF rated 6 month refrigerator filters flowing .75 gpm - .80 gpm.

PRODUCE PRESERVER

An ethylene-absorbing cartridge that extends the freshness of produce.** It helps neutralize the over-ripening effects of ethylene gas that is naturally emitted by certain fruits and vegetables.

** Based on commonly purchased produce.





SIDE-BY-SIDE REFRIGERATORS



KRSC500E - 36"

CONFIGURATIONS

- Counter-Depth

COLORS

- Stainless Steel (SS)

CAPACITIES (Cu. Ft.)

- 19.8 Total Volume

PERFORMANCE FEATURES

- Preserva® Food Care System
- Adaptive Defrost
- Humidity-Controlled Crisper
- Automatic Ice Maker
- In-Door-Ice® System with Light
- Through-the-Door Ice & Water Dispenser
- EveryDrop® Ice & Water Filter
- Light-Touch Controls
- Control Lockout
- Measured Fill
- Unit Conversion (oz/cups/liters)



KRSC503E - 36"

CONFIGURATIONS

- Counter-Depth

COLORS

- Stainless Steel (SS)

CAPACITIES (Cu. Ft.)

- 22.6 Total Volume

PERFORMANCE FEATURES

- Preserva® Food Care System
- Adaptive Defrost
- Humidity-Controlled Crisper
- Automatic Ice Maker
- In-Door-Ice® System with Light
- Through-the-Door Ice & Water Dispenser
- EveryDrop® Ice & Water Filter
- Light-Touch Controls
- Control Lockout
- Measured Fill
- Unit Conversion (oz/cups/liters)



KRSC505E - 36"

CONFIGURATIONS

- Full-Depth

COLORS

- White (WH)
- Black (BL)
- Stainless Steel (SS)

CAPACITIES (Cu. Ft.)

- 24.8 Total Volume

PERFORMANCE FEATURES

- Preserva® Food Care System
- Adaptive Defrost
- Humidity-Controlled Crisper
- Automatic Ice Maker
- In-Door-Ice® System with Light
- Through-the-Door Ice & Water Dispenser
- EveryDrop® Ice & Water Filter
- Light-Touch Controls
- Control Lockout
- Measured Fill
- Unit Conversion (oz/cups/liters)

CONTROL FEATURES

- Temperature
- Over Temperature Alarm
- Door Alarm
- Water Filter Status Indicator
- Max Ice
- Max Cool
- Sabbath Mode (Star-K Certified)

DESIGN FEATURES

- Adjustable Spill-Resistant Glass Shelves with Spill Shield Technology
- Adjustable Door Bins with Removable Insert
- Gallon Door Storage
- Metal Wine Rack
- 3 Adjustable Full-Width Freezer Shelves
- 2 Freezer Bins
- 3 Adjustable Full-Width Freezer Door Bins
- LED Lighting with Tower
- Hidden Hinges
- Front-Adjustable Leveling Legs
- Metallic Trim

CONTROL FEATURES

- Temperature
- Over Temperature Alarm
- Door Alarm
- Water Filter Status Indicator
- Max Ice
- Max Cool
- Sabbath Mode (Star-K Certified)

DESIGN FEATURES

- Adjustable Spill-Resistant Glass Shelves with Spill Shield Technology
- Adjustable Door Bins with Removable Insert
- Gallon Door Storage
- Metal Wine Rack
- 3 Adjustable Full-Width Freezer Shelves
- 2 Freezer Bins
- 3 Adjustable Full-Width Freezer Door Bins
- LED Lighting with Tower
- Hidden Hinges
- Front-Adjustable Leveling Legs
- Metallic Trim

CONTROL FEATURES

- Temperature
- Over Temperature Alarm
- Door Alarm
- Water Filter Status Indicator
- Max Ice
- Max Cool
- Sabbath Mode (Star-K Certified)

DESIGN FEATURES

- Adjustable Spill-Resistant Glass Shelves with Spill Shield Technology
- Adjustable Door Bins with Removable Insert
- Gallon Door Storage
- Metal Wine Rack
- 3 Adjustable Full-Width Freezer Shelves
- 2 Freezer Bins
- 3 Adjustable Full-Width Freezer Door Bins
- LED Lighting with Tower
- Hidden Hinges
- Front-Adjustable Leveling Legs
- Metallic Trim

ENERGY EFFICIENCY

- ENERGY STAR® Qualified

Red text = step-up feature

**SPECIALTY
REFRIGERATION**

**SPECIALTY
REFRIGERATORS**

**REFRIGERATOR
DRAWERS**

**BEVERAGE
CENTERS**

WINE CELLARS

**AUTOMATIC
ICE MAKERS**





Installation Options

- ▲ Refrigerators/Drawers
- ▼ Premium Features

- ▲ Beverage/Wine Cellars
- ▼ Premium Features

- ▲ Automatic Ice Makers
- ▼ Premium Features

Model Lineup

**SPECIALTY
REFRIGERATION**



TAKE REFRIGERATION BEYOND THE KITCHEN

More consumers are remodeling their homes and want to have refreshments where they cook and entertain. Whether it's the wine enthusiast who wants to preserve the quality of their collection, or the entertainer who simply desires to have food and/or beverages close at hand, KitchenAid® specialty refrigeration provides stylish and versatile appliance options that can extend beyond the kitchen to turn virtually any room into an entertaining zone.

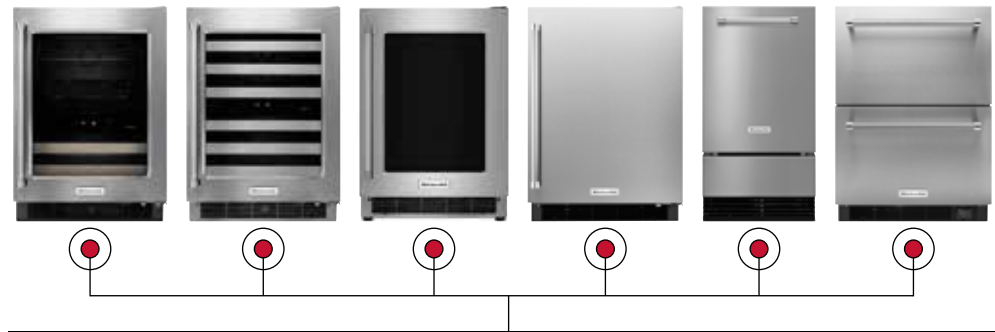

Home Theater
Island/Prep Area

Mini Bar
Home Office

Fitness Room
Garage

Outdoor Patio
Basement

THE PERFECT PAIR

The modular design of KitchenAid® specialty refrigeration products creates an opportunity to pair two or more appliances in different areas of the home, particularly in large homes that have a smaller kitchen. Another option is to place two specialty appliances next to each other so the doors swing open similar to a side-by-side or French door refrigerator.





Ice makers come in 15- or 18-inch widths making them an ideal option in narrow spaces like the end of a cabinet run.

BUILT-IN INSTALLATIONS

Most specialty refrigeration appliances are 24 inches wide, allowing them to fit in the space of a standard base cabinet.

Overlay panel-ready models accept custom panels, giving specialty refrigeration appliances a more integrated look with surrounding cabinets. Models with glass inserts accept an overlay-style frame. Custom panels and handles must be ordered separately.



FREESTANDING INSTALLATIONS

Although most often considered as part of a built-in design, specialty refrigeration appliances have the option of adding stainless steel side panels to create a more finished look in installations where one or both sides will be visible.





RETHINK THE REFRIGERATOR

Whether or not the refrigerator is a focal point of a kitchen, specialty refrigerators and drawer refrigerators can be simple, elegant solutions to bring refreshments into areas that fit lifestyles.

SPECIALTY REFRIGERATORS

In the kitchen or in the home theater, an under counter refrigerator allows essential beverages and appetizers to be close at hand so that guests can truly make themselves at home. The 24-inch design allows them to fit in the space of a common base cabinet.



Select refrigerators feature a window in the door that is enhanced by proximity-activated Auto-Light Interior LED Lighting.



A drawer refrigerator **in an island** is an easy way to keep prep ingredients close at hand.

DOUBLE-DRAWER REFRIGERATORS

Double-drawer refrigerators provide supplemental refrigeration in the space of a 24-inch base cabinet. Each drawer is deep enough to hold large, bulky items. And with two drawers, food can be organized for preparation or entertaining.

DOUBLE-DRAWER REFRIGERATOR/FREEZER COMBINATIONS

Two independent drawers create options for managing storage of frozen and refrigerated foods. The combination also features an automatic ice maker and base-grille water filtration system with an EveryDrop® Ice & Water Filter.





PREMIUM FEATURES

SPECIALTY REFRIGERATORS

1 AUTO-LIGHT INTERIOR LED LIGHTING

Proximity-activated lighting makes it easy to find items without having to open the door. Top-mounted LED lights ramp on when approaching the appliance, and gradually turn off when not needed.

2 TOUCH CONTROLS

An easy-to-use electronic interface that allows pleasant and precise control over temperatures and settings.

UV-PROTECTED THERMAL GLASS DOOR

Ultraviolet (UV) rays can cause internal temperatures to rise beyond their set point which can damage wine. UV protection on the door filters UV rays to help maintain the internal temperature.

SATINGLIDE® METAL-FRONT RACKS

Provide smooth movement even when fully loaded and feature a canted design that allows bottles to be stored end to end.

SPILL-RESISTANT GLASS SHELVES

Help contain spills and stop them from spreading within the refrigerator.

DRAWER REFRIGERATORS

3 TOUCH CONTROLS

An easy-to-use electronic interface that allows pleasant and precise control over temperatures and settings.

AUTOMATIC ICE MAKER

Ensures a consistent supply of ice for entertaining or any occasion.

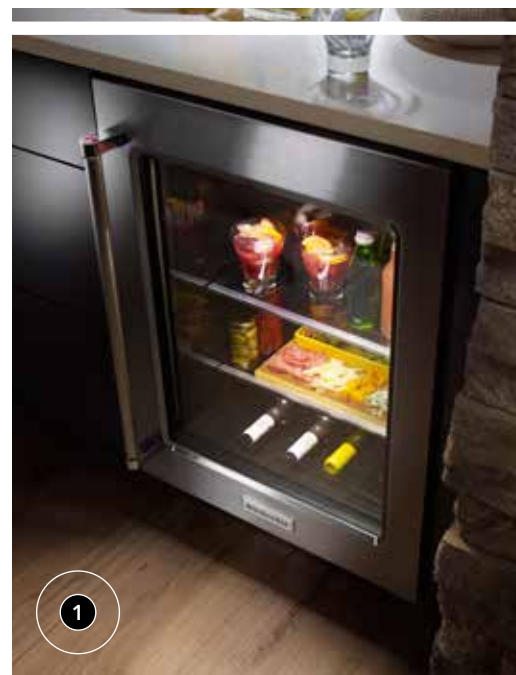



TWO ARE BETTER THAN ONE

TRUE INDEPENDENT TEMPERATURE ZONES

With two truly independent temperature zones, KitchenAid® beverage centers and wine cellars help optimize storage for different types of wines as well as fresh food items that require different climates.

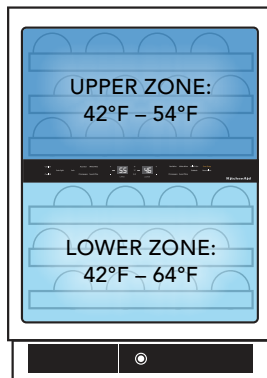
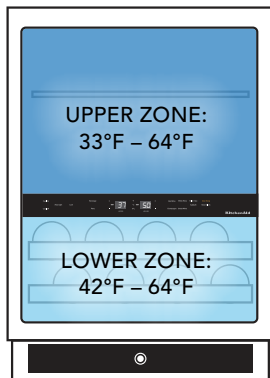

The **Beverage Center** is ideal for garnishes and beverage cans while still leaving room for multiple bottles of wine.

The **Wine Cellar** is for anyone who enjoys wine. With a 46-bottle capacity, there's plenty of reasons to stock up on personal favorites.





PREMIUM FEATURES

1 TOUCH CONTROLS

An easy-to-use electronic interface that allows precise control over temperatures and settings.

2 AUTO-LIGHT INTERIOR LED LIGHTING

Proximity-activated lighting makes it easy to find items without having to open the door. Top-mounted LED lights ramp on when approaching the appliance, and gradually turn off when not needed.

3 SATINGLIDE® CANTED RACKS

Provide smooth movement even when fully loaded and feature a canted design that allows bottles to be stored end to end. Depending on the model, the racks have a wood or metal front.

UV-PROTECTED THERMAL GLASS DOOR

Ultraviolet (UV) rays can cause internal temperatures to rise beyond their set point which can damage wine. UV protection on the door filters UV rays to help maintain the internal temperature.

CAPACITY

Allows convenient storage and display of favorite wines.

Beverage Center: 14 wine bottles
Wine Cellar: 46 wine bottles

SPILL-RESISTANT GLASS SHELF

The beverage center has a shelf which helps contain spills and stop them from spreading within the refrigerator.

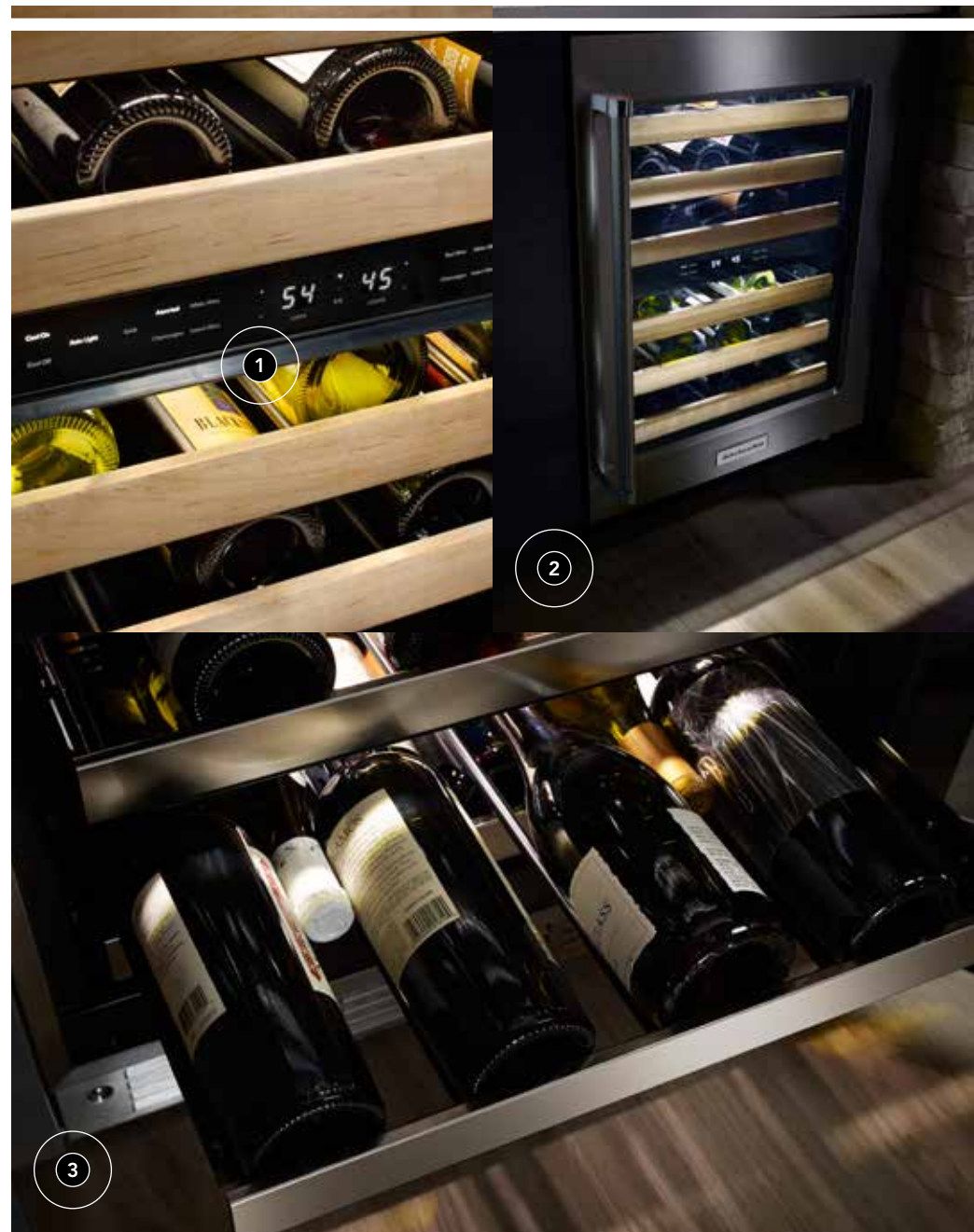



THE CLEAR WAY TO ICE THE PARTY

Consumers who purchase ice makers prefer KitchenAid® Clear Ice, which is favored for its versatility and premium qualities that are perfect for entertaining. And with 50 pounds of ice produced per 24 hours*, the ice will last as long as the party!

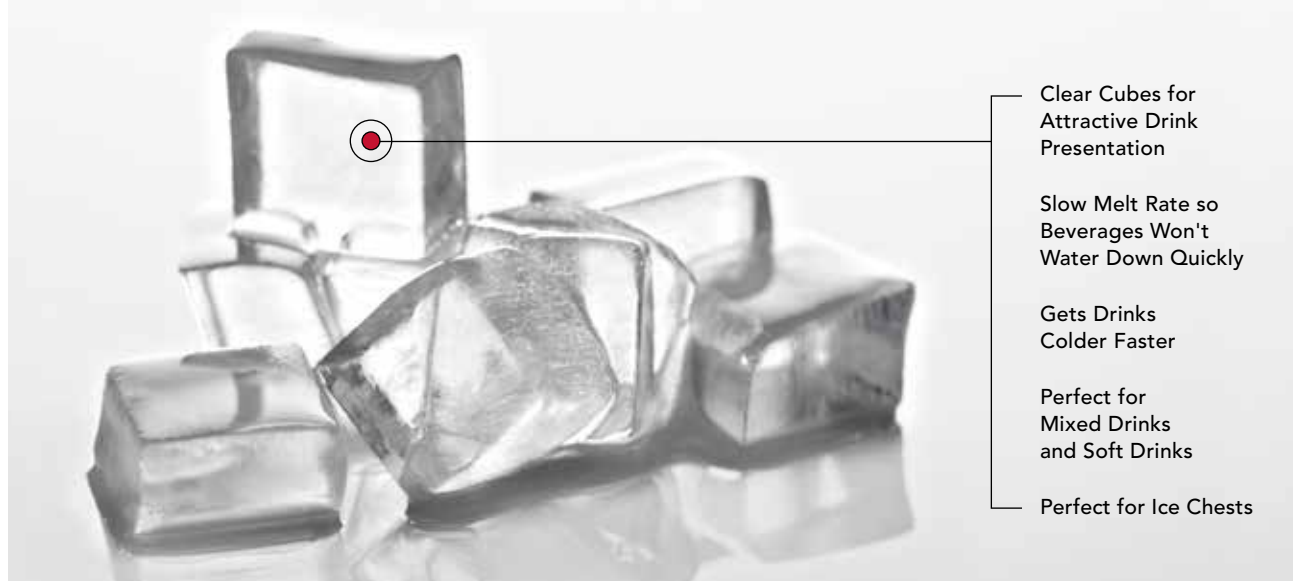

Clear Cubes for Attractive Drink Presentation

Slow Melt Rate so Beverages Won't Water Down Quickly

Gets Drinks Colder Faster

Perfect for Mixed Drinks and Soft Drinks

Perfect for Ice Chests



HERE'S HOW KITCHENAID® ICE MAKERS MAKE THE MOST PREFERRED ICE**

Fresh, filtered water enters the machine and is constantly circulated over a freezing plate. As the water freezes, the minerals are rejected. This produces a sheet of ice with a low mineral content.

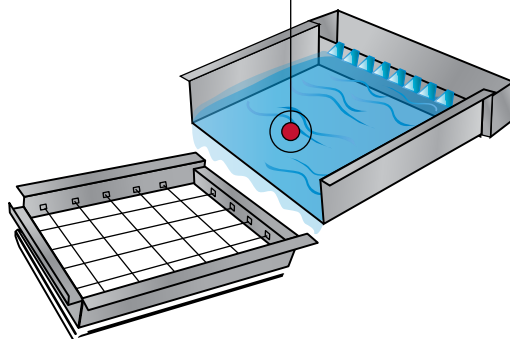

When the desired thickness is reached, the ice sheet is released and slides onto a cutter grid.

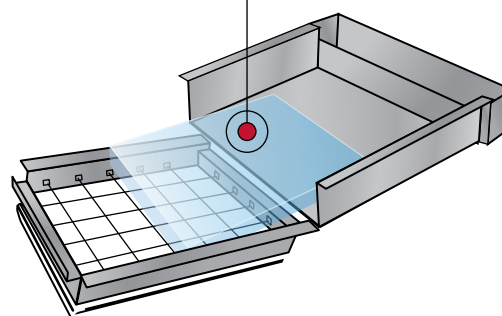

The grid divides the sheet into individual $\frac{3}{4}$ " x $\frac{3}{4}$ " x $\frac{1}{2}$ " cubes. The water containing the minerals drains out of the ice maker after each freezing cycle.

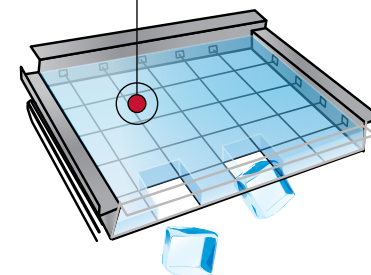

* When Max Ice is selected. / ** Among leading brands based on third party survey testing.



PREMIUM FEATURES

1 ICE CAPACITY

Ensures a generous supply of fresh ice is conveniently at your fingertips.

18-inch models: Holds 35 lbs. of ice

15-inch models: Holds 25 lbs. of ice

INTEGRATED FILTER

This feature helps ensure great-tasting clear ice cubes and a clean, efficient ice maker by filtering sediment in the water and helping to prevent scale formation.

DROP-DOWN DOOR

A door style that pulls down from the front, removing any side hinges and eliminating the need to accommodate them when installing with adjoining cabinetry.



ENHANCE YOUR OUTDOOR ENTERTAINING

Our outdoor-rated model (KUIO18NNZ) features a weather-resistant design that includes welded stainless steel construction, which is one reason it's UL-approved for outdoor use.

MAX ICE

Selecting this option accelerates ice production by 56%, compared to normal mode, when ice is needed quickly.

3-YEAR LIMITED WARRANTY

One of the strongest warranties in the industry helps ensure purchase satisfaction and covers the entire product with a limited parts and labor warranty for the first three years and includes a limited (parts only) warranty on the sealed refrigeration system for the 4th and 5th year.

FACTORY-INSTALLED DRAIN PUMP

Allows installation within 10 feet of a drain, in any direction.





UNDERCOUNTER REFRIGERATOR / REFRIGERATOR DRAWERS



KURR104E
KURL104E



KURR204E
KURL204E



KURR304E
KURL304E



KUDR204E



KUDF204E

CONFIGURATION

- Undercounter Refrigerator
- Right-Hand Door Swing (KURR104E)
- Left-Hand Door Swing (KURL104E)

CONFIGURATION

- Undercounter Refrigerator
- Right-Hand Door Swing (KURR204E)
- Left-Hand Door Swing (KURL204E)

CONFIGURATION

- Undercounter Refrigerator
- Right-Hand Door Swing (KURR304E)
- Left-Hand Door Swing (KURL304E)

CONFIGURATION

- Refrigerator Drawers

CONFIGURATION

- Refrigerator/Freezer Drawers

COLORS

- Stainless Steel (SB)
- Panel-Ready (PA)

COLORS

- Stainless Steel (SB)

COLORS

- Stainless Steel (SS)

COLORS

- Stainless Steel (SS)
- Panel-Ready (PA)

COLORS

- Stainless Steel (SS)
- Panel-Ready (PA)

CAPACITIES

- 4.9 Cu. Ft.

CAPACITIES

- 5.1 Cu. Ft.

CAPACITIES

- 5.1 Cu. Ft.

CAPACITIES

- 4.7 Cu. Ft. (2.5 Cu. Ft. Upper Drawer and 2.2 Cu. Ft. Lower Drawer)

CAPACITIES

- 4.7 Cu. Ft. (2.5 Cu. Ft. Upper Drawer and 2.2 Cu. Ft. Lower Drawer)

PERFORMANCE FEATURES

- Adjustable Temperature Control
- Auto Defrost
- Max Cool

PERFORMANCE FEATURES

- Adjustable Temperature Control
- Auto Defrost
- Max Cool
- **UV-Protected Thermal Glass Door**

PERFORMANCE FEATURES

- Adjustable Temperature Control
- Auto Defrost
- Max Cool
- UV-Protected Thermal Glass Door

PERFORMANCE FEATURES

- Two Refrigerator Drawers
- Auto Defrost
- Max Cool

- Sabbath Mode
- Temperature Presets (Upper Drawer: *Produce/Beverage/Assorted/Meat*)
- Temperature Presets (Lower Drawer: *Produce/Beverage/Assorted/Meat*)

PERFORMANCE FEATURES

- Refrigerator/Freezer Drawers
- Auto Defrost
- Max Cool
- Automatic Ice Maker w/EveryDrop® Ice & Water Filter
- Sabbath Mode
- Temperature Presets (Upper Drawer: *Produce/Beverage/Assorted/Meat*)
- Temperature Presets (Lower Drawer: *Soft Serve/Assorted/Spirits/Deep Freeze*)

DESIGN FEATURES

- 2 Fixed Full-Depth Spill-Resistant Glass Shelves (Black Front)
- ¾-Depth Spill-Resistant Glass Shelf (Black Front)
- Clear Door Bins
- LED Interior Lighting

- Capacitive Touch Controls

- Built-In or Freestanding Installation
- Adjustable Leveling Legs
- Magnetic Door Gasket

DESIGN FEATURES

- 2 Fixed Full-Depth Spill-Resistant Glass Shelves (Black Front)
- ¾-Depth Spill-Resistant Glass Shelf (Black Front)
- **Proximity-Activated LED Interior Lighting**
- Capacitive Touch Controls

- Built-In or Freestanding Installation
- Adjustable Leveling Legs
- Magnetic Door Gasket

DESIGN FEATURES

- 2 Fixed Full-Depth Spill-Resistant Glass Shelves (**Stainless Steel Front**)
- ¾-Depth Spill-Resistant Glass Shelf (**Stainless Steel Front**)
- Proximity-Activated LED Interior Lighting
- Capacitive Touch Controls
- **Stainless Steel Cabinet and Base Grille**
- Built-In or Freestanding Installation
- Adjustable Leveling Legs
- Magnetic Door Gasket

DESIGN FEATURES

- Full-Width Drawer Mats

- Drawer Dividers
- LED Interior Lighting

- Capacitive Touch Controls
- Black Cabinet Exterior

- Built-In or Freestanding Installation
- Adjustable Leveling Legs

DESIGN FEATURES

- Full-Width Drawer Mats

- Drawer Dividers
- LED Interior Lighting

- Capacitive Touch Controls
- Black Cabinet Exterior

- Built-In or Freestanding Installation
- Adjustable Leveling Legs

Red text = step-up feature

Installation Options

▲ Refrigerators/Drawers
▼ Premium Features

▲ Beverage/Wine Cellars
▼ Premium Features

▲ Automatic Ice Makers
▼ Premium Features

Model Lineup

SPECIALTY
REFRIGERATION



BEVERAGE CENTERS / WINE CELLARS



KUBR204E
KUBL204E

CONFIGURATION

- Beverage Center
- Right-Hand Door Swing (KUBR204E)
- Left-Hand Door Swing (KUBL204E)

COLORS

- Stainless Steel (SS)
- Panel-Ready (PA)

CAPACITIES

- 4.8 Cu. Ft. / 14 Wine Bottle

PERFORMANCE FEATURES

- Two Temperature-Controlled Zones
- Auto Defrost
- UV-Protected Thermal Glass Door

DESIGN FEATURES

- Spill-Resistant Glass Shelf
- SatinGlide® Extendable Racks with Stainable Maple Trim (Oil Based)
- 2 Canted Wine Racks
- Capacitive Touch Controls
- Proximity-Activated LED Interior Lighting
- Built-In or Freestanding Installation
- Adjustable Leveling Legs



KUBR304E
KUBL304E

CONFIGURATION

- Beverage Center
- Right-Hand Door Swing (KUBR304E)
- Left-Hand Door Swing (KUBL304E)

COLORS

- Stainless Steel (SS)

CAPACITIES

- 4.8 Cu. Ft. / 14 Wine Bottle

PERFORMANCE FEATURES

- Two Temperature-Controlled Zones
- Auto Defrost
- UV-Protected Thermal Glass Door

DESIGN FEATURES

- Spill-Resistant Glass Shelf with Metal Trim
- SatinGlide® Extendable Racks with Metal Trim
- 2 Canted Wine Racks
- Capacitive Touch Controls
- Proximity-Activated LED Interior Lighting
- Built-In or Freestanding Installation
- Adjustable Leveling Legs



KUWR204E
KUWL204E

CONFIGURATION

- Wine Cellar
- Right-Hand Door Swing (KUWR204E)
- Left-Hand Door Swing (KUWL204E)

COLORS

- Stainless Steel (SS)
- Panel-Ready (PA)

CAPACITIES

- 4.7 Cu. Ft. / 46 Wine Bottle

PERFORMANCE FEATURES

- True Dual Temperature Zones
- Auto Defrost
- UV-Protected Thermal Glass Door

DESIGN FEATURES

- SatinGlide® Extendable Racks with Stainable Maple Trim (Oil Based)
- 6 Canted Wine Racks
- Capacitive Touch Controls
- Proximity-Activated LED Interior Lighting
- Built-In or Freestanding Installation
- Adjustable Leveling Legs



KUWR304E
KUWL304E

CONFIGURATION

- Wine Cellar
- Right-Hand Door Swing (KUWR304E)
- Left-Hand Door Swing (KUWL304E)

COLORS

- Stainless Steel (SS)

CAPACITIES

- 4.7 Cu. Ft. / 46 Wine Bottle

PERFORMANCE FEATURES

- True Dual Temperature Zones
- Auto Defrost
- UV-Protected Thermal Glass Door

DESIGN FEATURES

- SatinGlide® Extendable Racks with Metal Trim
- 6 Canted Wine Racks
- Capacitive Touch Controls
- Proximity-Activated LED Interior Lighting
- Built-In or Freestanding Installation
- Adjustable Leveling Legs



AUTOMATIC ICE MAKERS



KUID308E/KUID508E - 18"

COLORS

- Stainless Steel (SS)

CAPACITIES

- 35-lb. Storage Capacity
- Makes up to 50 lbs. per 24 Hours

PERFORMANCE FEATURES

- Clear Ice Technology
- Max Ice
- Integrated Filter
- Drain Pump – 1901A** (KUID308E)
Built-In Drain Pump (KUID508E)

DESIGN FEATURES

- 3-Year Limited Warranty
- Built-In or Freestanding Installation
- LED Lighting in Interior Bin



KUIS18PNZ - 18"

COLORS

- White (WH)
- Black (BL)

CAPACITIES

- 35-lb. Storage Capacity
- Makes up to 50 lbs. per 24 Hours

PERFORMANCE FEATURES

- Clear Ice Technology
- Max Ice
- Integrated Filter
- Built-In Drain Pump

DESIGN FEATURES

- 3-Year Limited Warranty
- Built-In or Freestanding Installation
- LED Lighting in Interior Bin



KUIO18NNZ - 18"

COLORS

- Stainless Steel (SS)

CAPACITIES

- 35-lb. Storage Capacity
- Makes up to 50 lbs. per 24 Hours

PERFORMANCE FEATURES

- Clear Ice Technology
- Max Ice
- Integrated Filter
- Drain Pump – 1901A**

DESIGN FEATURES

- **UL Approved for Outdoor Use**
- 3-Year Limited Warranty
- Built-In or Freestanding Installation
- LED Lighting in Interior Bin



KUIX305E/KUIX505E - 15"

COLORS

- White (WH)*
- Black (BL)*
- Stainless Steel (SS)

CAPACITIES

- 25-lb. Storage Capacity
- Makes up to 50 lbs. per 24 Hours

PERFORMANCE FEATURES

- Clear Ice Technology
- Max Ice
- Integrated Filter
- Drain Pump – 1901A** (KUIX305E)
Built-In Drain Pump (KUIX505E)

DESIGN FEATURES

- 3-Year Limited Warranty
- Built-In or Freestanding Installation
- LED Lighting in Interior Bin



KUIC15POZ - 15"

COLORS

- Panel-Ready (PA)

CAPACITIES

- 25-lb. Storage Capacity
- Makes up to 50 lbs. per 24 Hours

PERFORMANCE FEATURES

- Clear Ice Technology
- Max Ice
- Integrated Filter
- Built-In Drain Pump

DESIGN FEATURES

- 3-Year Limited Warranty
- Built-In or Freestanding Installation
- LED Lighting in Interior Bin

Red text = step-up feature

* Model KUIX305E only. / ** Not included.

KitchenAid®

®/™ ©2015 KitchenAid. All rights reserved.
All other trademarks are owned by their respective companies.
Specifications are subject to change without notice.

8374AdZw415

FREESTANDING REFRIGERATION

KitchenAid®



KT140367B